

U16A XC2V6000-BF957	
ADC0_D15	adc0_d0
ADC0_D16	adc0_d1
ADC0_D17	adc0_d2
ADC0_D18	adc0_d3
ADC0_D19	adc0_d4
ADC0_D20	adc0_d5
ADC0_D21	adc0_d6
ADC0_D22	adc0_d7
ADC0_D23	adc0_d8
ADC0_D24	adc0_d9
ADC0_D25	adc0_d10
ADC0_D26	adc0_d11
ADC0_D27	
ADC0_D28	
ADC0_D29	
ADC0_D30	
ADC0_D31	
ADC0_D32	
ADC0_D33	
ADC0_D34	
ADC0_D35	
ADC0_D36	
ADC0_D37	
ADC0_D38	
ADC0_D39	
ADC0_D40	
ADC0_D41	
ADC0_D42	
ADC0_D43	
ADC0_D44	
ADC0_D45	
ADC0_D46	
ADC0_D47	
ADC0_D48	
ADC0_D49	
ADC0_D50	
ADC0_D51	
ADC0_D52	
ADC0_D53	
ADC0_D54	
ADC0_D55	
ADC0_D56	
ADC0_D57	
ADC0_D58	
ADC0_D59	
ADC0_D60	
ADC0_D61	
ADC0_D62	
ADC0_D63	
ADC0_D64	
ADC0_D65	
ADC0_D66	
ADC0_D67	
ADC0_D68	
ADC0_D69	
ADC0_D70	
ADC0_D71	
ADC0_D72	
ADC0_D73	
ADC0_D74	
ADC0_D75	
ADC0_D76	
ADC0_D77	
ADC0_D78	
ADC0_D79	
ADC0_D80	
ADC0_D81	
ADC0_D82	
ADC0_D83	
ADC0_D84	
ADC0_D85	
ADC0_D86	
ADC0_D87	
ADC0_D88	
ADC0_D89	
ADC0_D90	
ADC0_D91	
ADC0_D92	
ADC0_D93	
ADC0_D94	
ADC0_D95	
ADC0_D96	
ADC0_D97	
ADC0_D98	
ADC0_D99	
ADC0_D100	
ADC1_D1	adc1_d0
ADC1_D2	adc1_d1
ADC1_D3	adc1_d2
ADC1_D4	adc1_d3
ADC1_D5	adc1_d4
ADC1_D6	adc1_d5
ADC1_D7	adc1_d6
ADC1_D8	adc1_d7
ADC1_D9	adc1_d8
ADC1_D10	adc1_d9
ADC1_D11	adc1_d10
ADC1_D12	adc1_d11
ADC1_D13	
ADC1_D14	
ADC1_D15	
ADC1_D16	
ADC1_D17	
ADC1_D18	
ADC1_D19	
ADC1_D20	
ADC1_D21	
ADC1_D22	
ADC1_D23	
ADC1_D24	
ADC1_D25	
ADC1_D26	
ADC1_D27	
ADC1_D28	
ADC1_D29	
ADC1_D30	
ADC1_D31	
ADC1_D32	
ADC1_D33	
ADC1_D34	
ADC1_D35	
ADC1_D36	
ADC1_D37	
ADC1_D38	
ADC1_D39	
ADC1_D40	
ADC1_D41	
ADC1_D42	
ADC1_D43	
ADC1_D44	
ADC1_D45	
ADC1_D46	
ADC1_D47	
ADC1_D48	
ADC1_D49	
ADC1_D50	
ADC1_D51	
ADC1_D52	
ADC1_D53	
ADC1_D54	
ADC1_D55	
ADC1_D56	
ADC1_D57	
ADC1_D58	
ADC1_D59	
ADC1_D60	
ADC1_D61	
ADC1_D62	
ADC1_D63	
ADC1_D64	
ADC1_D65	
ADC1_D66	
ADC1_D67	
ADC1_D68	
ADC1_D69	
ADC1_D70	
ADC1_D71	
ADC1_D72	
ADC1_D73	
ADC1_D74	
ADC1_D75	
ADC1_D76	
ADC1_D77	
ADC1_D78	
ADC1_D79	
ADC1_D80	
ADC1_D81	
ADC1_D82	
ADC1_D83	
ADC1_D84	
ADC1_D85	
ADC1_D86	
ADC1_D87	
ADC1_D88	
ADC1_D89	
ADC1_D90	
ADC1_D91	
ADC1_D92	
ADC1_D93	
ADC1_D94	
ADC1_D95	
ADC1_D96	
ADC1_D97	
ADC1_D98	
ADC1_D99	
ADC1_D100	
ADC2_D1	adc2_d0
ADC2_D2	adc2_d1
ADC2_D3	adc2_d2
ADC2_D4	adc2_d3
ADC2_D5	adc2_d4
ADC2_D6	adc2_d5
ADC2_D7	adc2_d6
ADC2_D8	adc2_d7
ADC2_D9	adc2_d8
ADC2_D10	adc2_d9
ADC2_D11	adc2_d10
ADC2_D12	adc2_d11
ADC2_D13	
ADC2_D14	
ADC2_D15	
ADC2_D16	
ADC2_D17	
ADC2_D18	
ADC2_D19	
ADC2_D20	
ADC2_D21	
ADC2_D22	
ADC2_D23	
ADC2_D24	
ADC2_D25	
ADC2_D26	
ADC2_D27	
ADC2_D28	
ADC2_D29	
ADC2_D30	
ADC2_D31	
ADC2_D32	
ADC2_D33	
ADC2_D34	
ADC2_D35	
ADC2_D36	
ADC2_D37	
ADC2_D38	
ADC2_D39	
ADC2_D40	
ADC2_D41	
ADC2_D42	
ADC2_D43	
ADC2_D44	
ADC2_D45	
ADC2_D46	
ADC2_D47	
ADC2_D48	
ADC2_D49	
ADC2_D50	
ADC2_D51	
ADC2_D52	
ADC2_D53	
ADC2_D54	
ADC2_D55	
ADC2_D56	
ADC2_D57	
ADC2_D58	
ADC2_D59	
ADC2_D60	
ADC2_D61	
ADC2_D62	
ADC2_D63	
ADC2_D64	
ADC2_D65	
ADC2_D66	
ADC2_D67	
ADC2_D68	
ADC2_D69	
ADC2_D70	
ADC2_D71	
ADC2_D72	
ADC2_D73	
ADC2_D74	
ADC2_D75	
ADC2_D76	
ADC2_D77	
ADC2_D78	
ADC2_D79	
ADC2_D80	
ADC2_D81	
ADC2_D82	
ADC2_D83	
ADC2_D84	
ADC2_D85	
ADC2_D86	
ADC2_D87	
ADC2_D88	
ADC2_D89	
ADC2_D90	
ADC2_D91	
ADC2_D92	
ADC2_D93	
ADC2_D94	
ADC2_D95	
ADC2_D96	
ADC2_D97	
ADC2_D98	
ADC2_D99	
ADC2_D100	
ADC3_D1	adc3_d0
ADC3_D2	adc3_d1
ADC3_D3	adc3_d2
ADC3_D4	adc3_d3
ADC3_D5	adc3_d4
ADC3_D6	adc3_d5
ADC3_D7	adc3_d6
ADC3_D8	adc3_d7
ADC3_D9	adc3_d8
ADC3_D10	adc3_d9
ADC3_D11	adc3_d10
ADC3_D12	adc3_d11
ADC3_D13	
ADC3_D14	
ADC3_D15	
ADC3_D16	
ADC3_D17	
ADC3_D18	
ADC3_D19	
ADC3_D20	
ADC3_D21	
ADC3_D22	
ADC3_D23	
ADC3_D24	
ADC3_D25	
ADC3_D26	
ADC3_D27	
ADC3_D28	
ADC3_D29	
ADC3_D30	
ADC3_D31	
ADC3_D32	
ADC3_D33	
ADC3_D34	
ADC3_D35	
ADC3_D36	
ADC3_D37	
ADC3_D38	
ADC3_D39	
ADC3_D40	
ADC3_D41	
ADC3_D42	
ADC3_D43	
ADC3_D44	
ADC3_D45	
ADC3_D46	
ADC3_D47	
ADC3_D48	
ADC3_D49	
ADC3_D50	
ADC3_D51	
ADC3_D52	
ADC3_D53	
ADC3_D54	
ADC3_D55	
ADC3_D56	
ADC3_D57	
ADC3_D58	
ADC3_D59	
ADC3_D60	
ADC3_D61	
ADC3_D62	
ADC3_D63	
ADC3_D64	
ADC3_D65	
ADC3_D66	
ADC3_D67	
ADC3_D68	
ADC3_D69	
ADC3_D70	
ADC3_D71	
ADC3_D72	
ADC3_D73	
ADC3_D74	
ADC3_D75	
ADC3_D76	
ADC3_D77	
ADC3_D78	
ADC3_D79	
ADC3_D80	
ADC3_D81	
ADC3_D82	
ADC3_D83	
ADC3_D84	
ADC3_D85	
ADC3_D86	
ADC3_D87	
ADC3_D88	
ADC3_D89	
ADC3_D90	
ADC3_D91	
ADC3_D92	
ADC3_D93	
ADC3_D94	
ADC3_D95	
ADC3_D96	
ADC3_D97	
ADC3_D98	
ADC3_D99	
ADC3_D100	

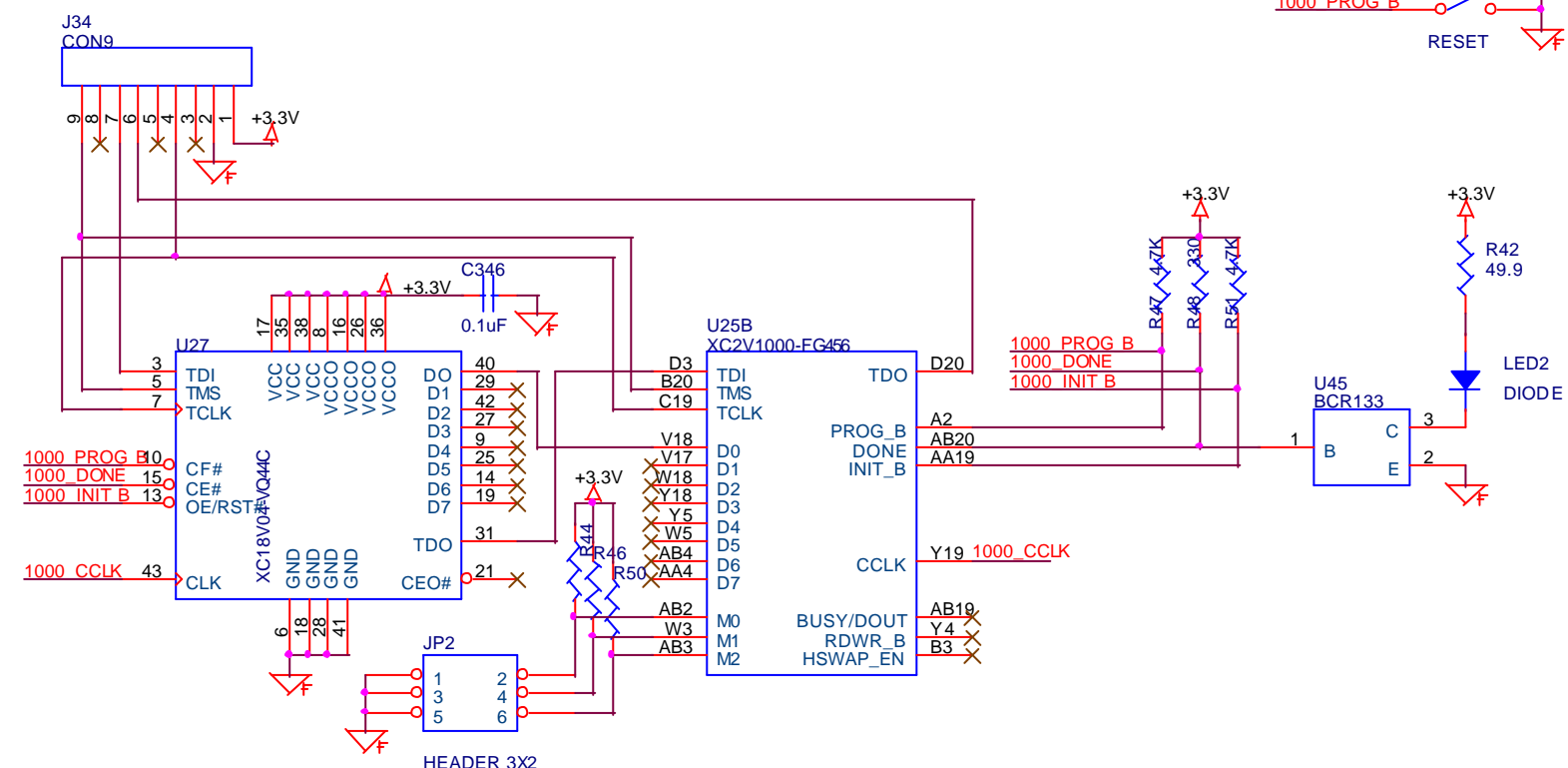

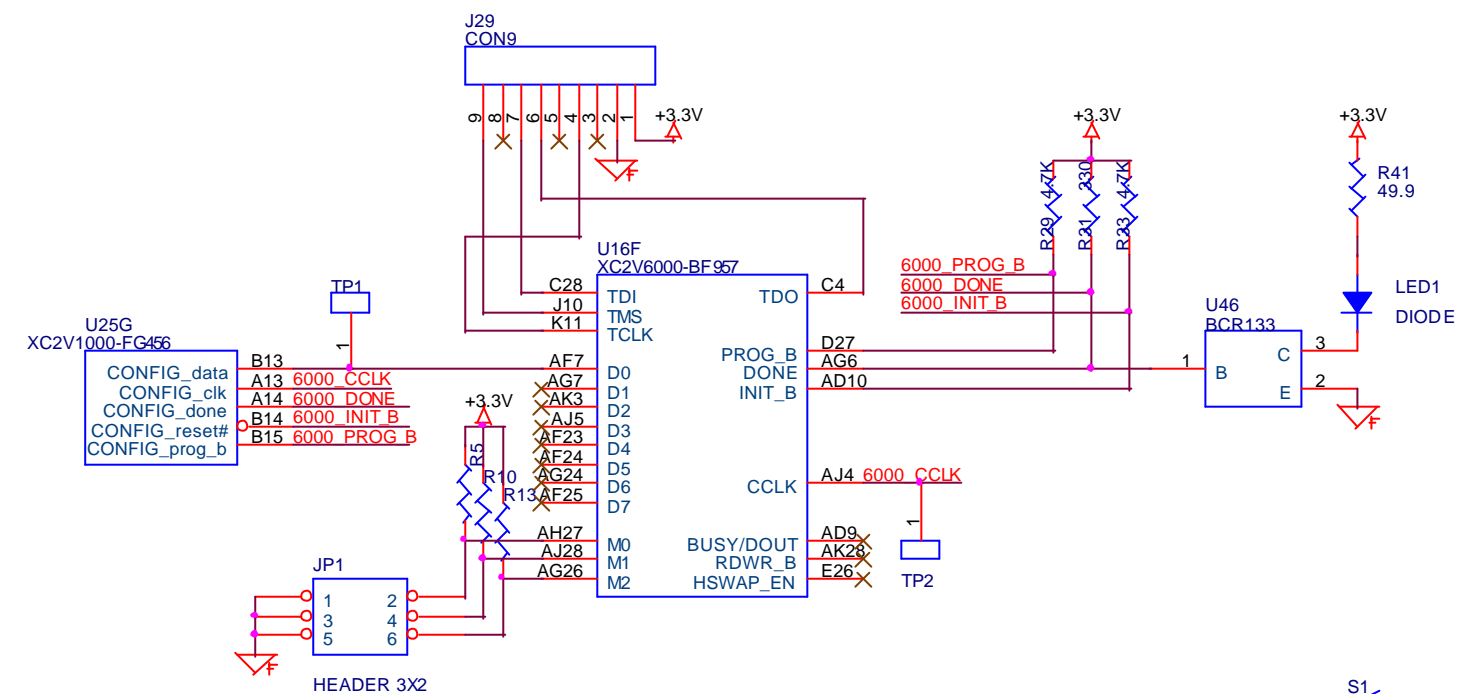

Title		Configuration
Size	Document Number	Rev 2
C	Aaron Parsons, UC Berkeley Copyright 2003	
Date:	Tuesday, July 13, 2004	Sheet 3 of 7

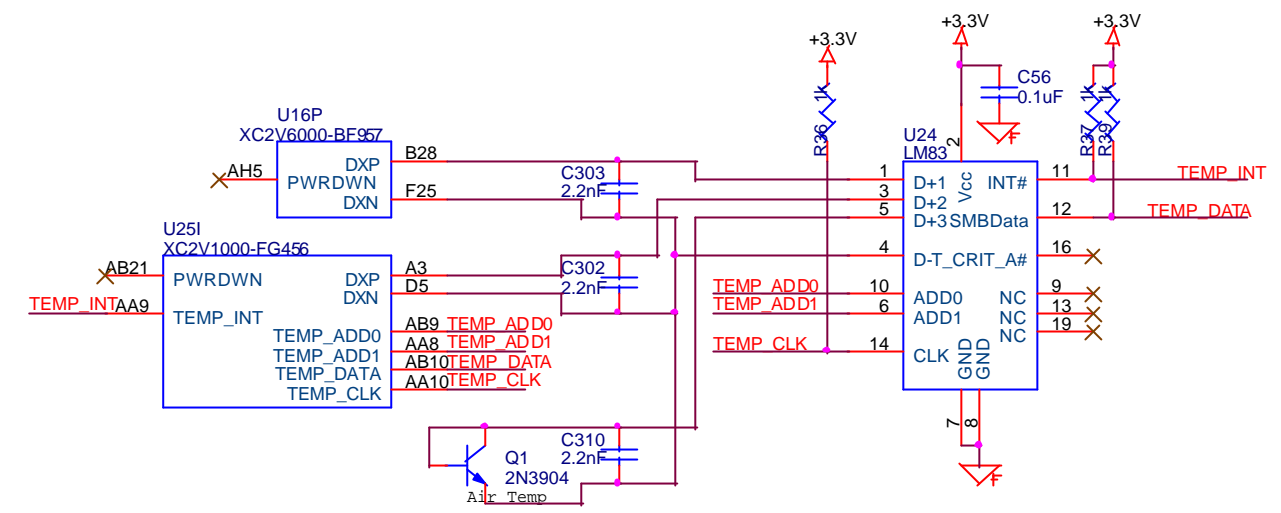
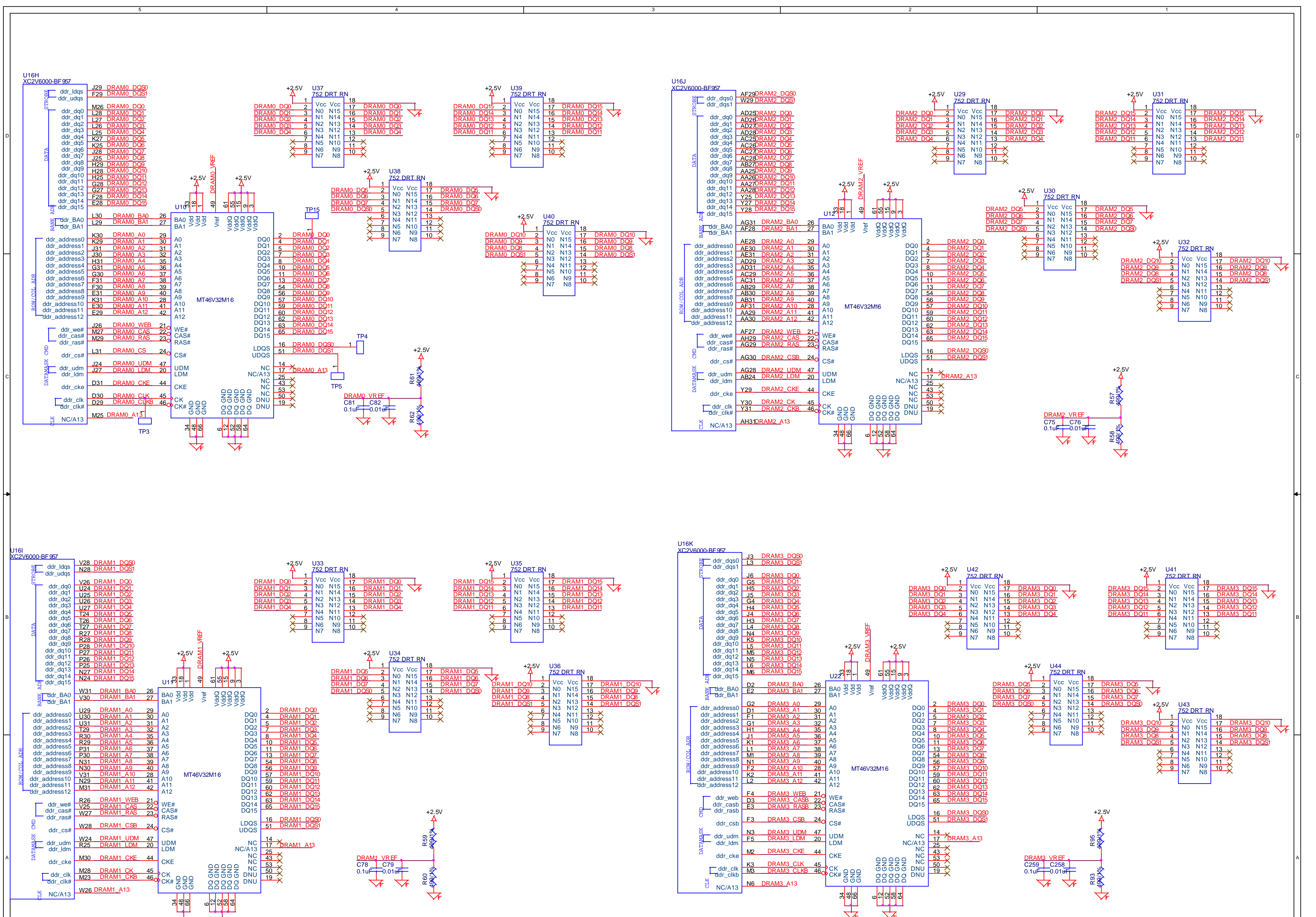

Title	DRAM	
Size	Document Number	Rev
C	Aaron Parsons, UC Berkeley Copyright 2003	2
Date:	Tuesday, July 13, 2004	Sheet 4 of 7

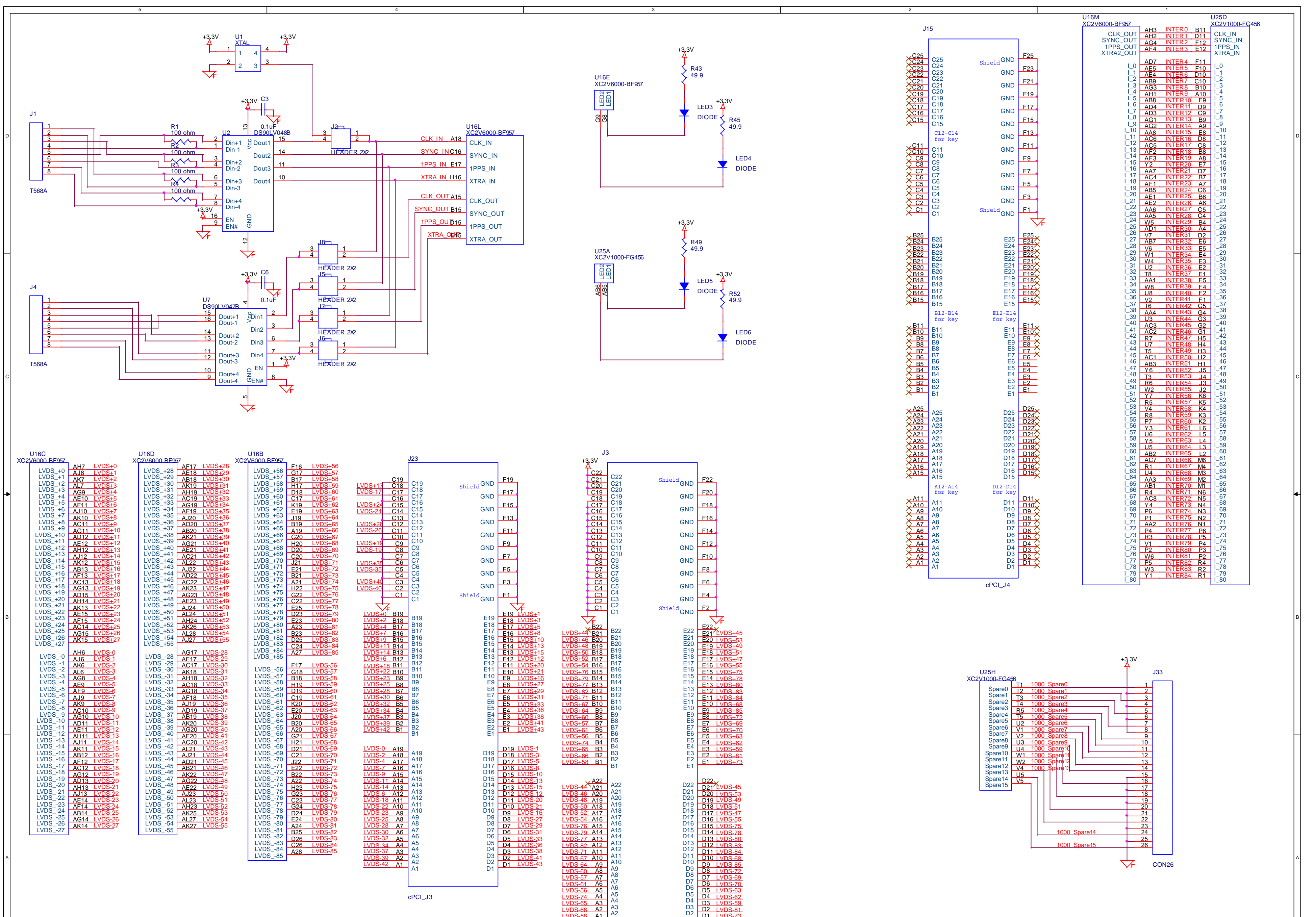

Title	Interconnect	
Size	Document Number	Rev
C	Aaron Parsons, UC Berkeley Copyright 2003	2
Date:	Tuesday, July 13, 2004	Sheet 5 of 7



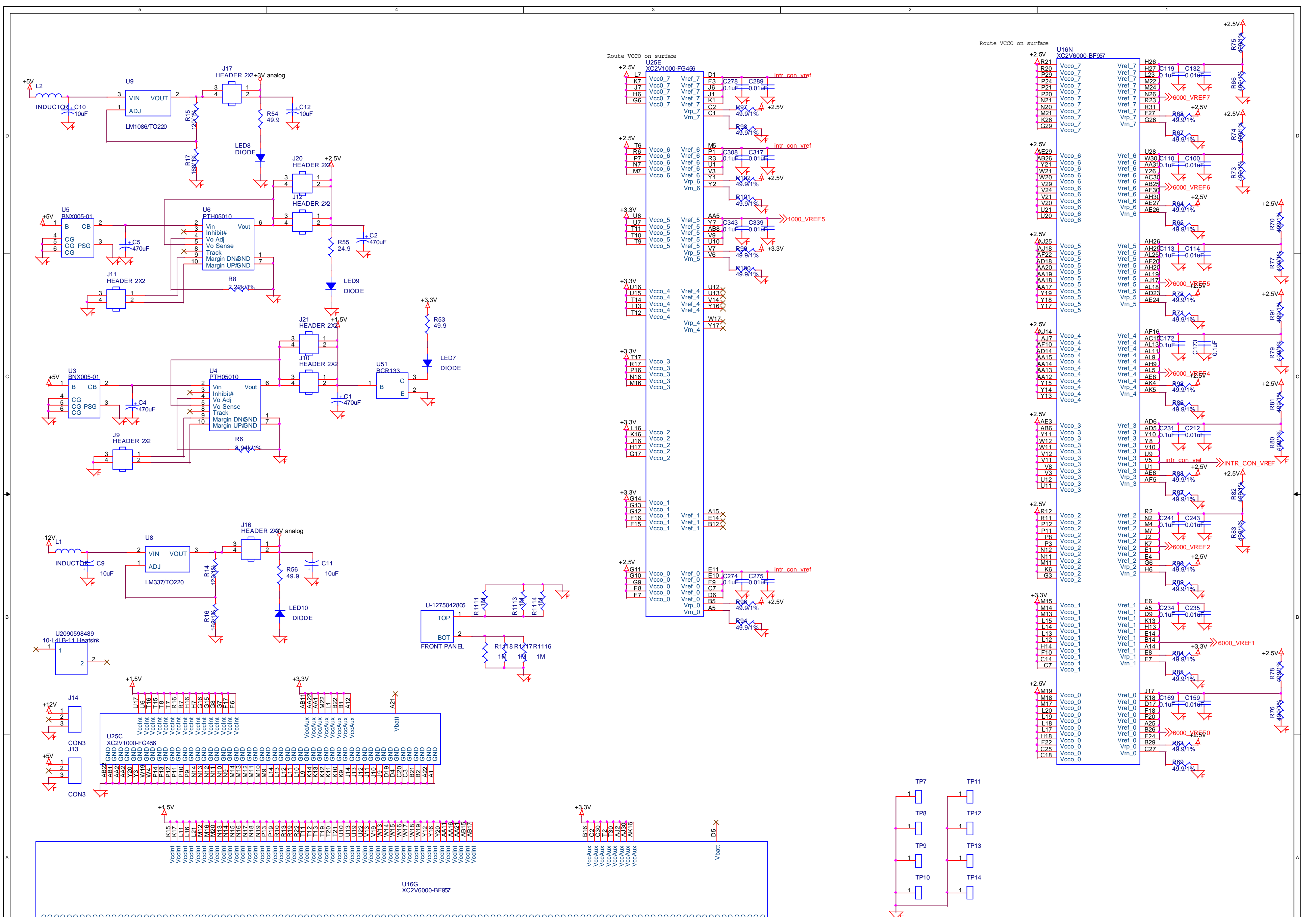

Title	Power
Size	Document Number
C	Aaron Parsons, UC Berkeley Copyright 2003
Date:	Tuesday, July 13, 2004
Sheet	7 of 7
Rev	2