

D

D

C

C

B

B

A

A

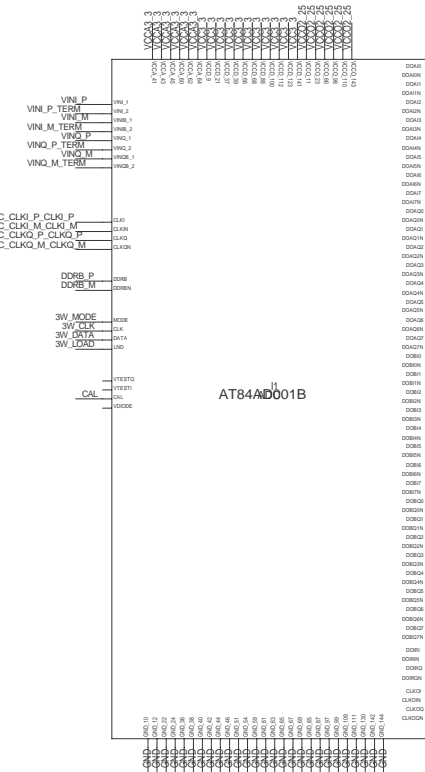

AT84AD001B

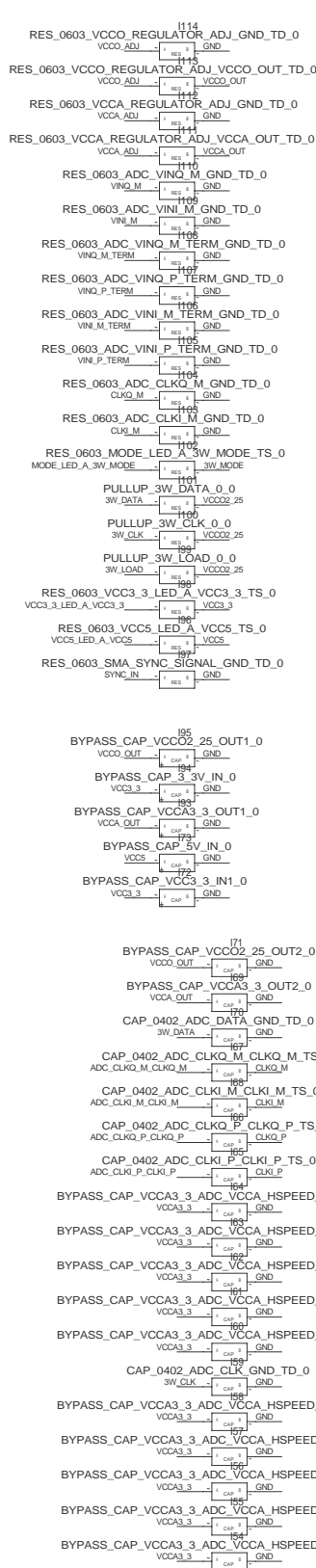
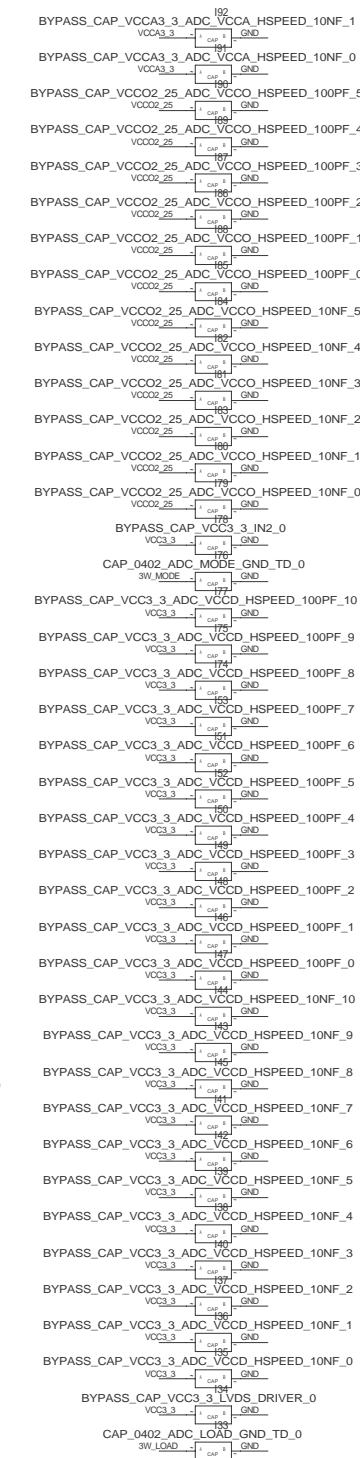
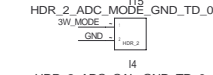
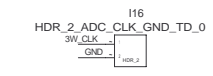
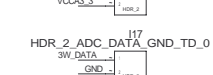
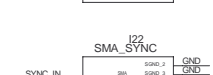
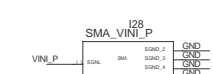
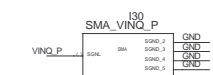
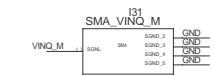
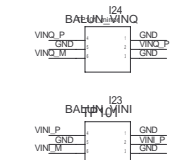
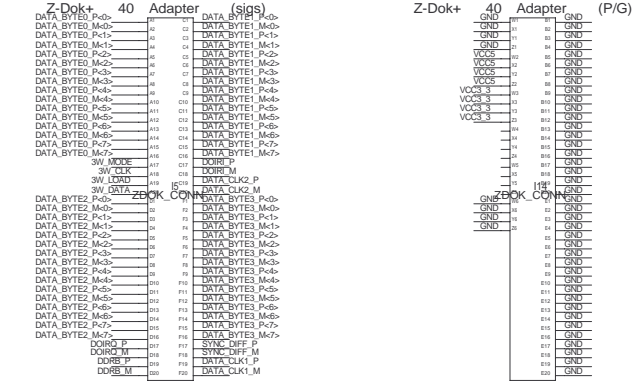
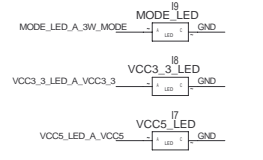
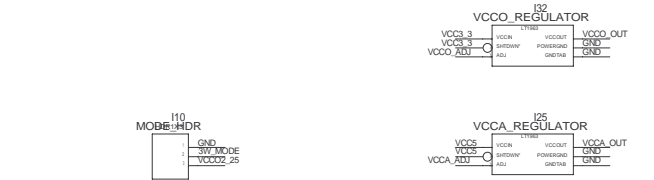

CHEN CHANG
EECS UC BERKELEY
BEE2 GROUP

BEE2 ADC BOARD

BERKELEY WIRELESS RESEARCH CENTER
2108 ALLSTON WAY
BERKELEY, CA 94704-1302
HTTP://BWR.EECS.BERKELEY.EDU

SIZE **D** SHEET 1 OF 1